

## B.A. SCREWS, BOLTS, NUTS AND PLAIN WASHERS

B.S. 57 : 1951

### SECTION ONE : SCREWS, BOLTS AND NUTS

**Method of manufacture.** Screws and bolts may be either turned from bars or forged.

**Material.** The material from which the screws, bolts and nuts are manufactured shall have an ultimate tensile stress of not less than the following :—

Steel	25 tons/sq. in.
Brass	20 tons/sq. in.
Aluminium alloy	20 tons/sq. in.

If the purchaser requires the screws, bolts and nuts to be manufactured from steel or brass of a higher tensile stress, or of another material, he shall specify the ultimate tensile stress of the material.

NOTE. The choice of alloy should normally be left to the manufacturer, but among suitable light alloys satisfying the requirement are the following :—

*For screws, bolts and nuts turned from wire or from the bar :* B.S. 1475 or B.S. 1476 respectively :

B.S. 1475 : 'Aluminium and aluminium alloy wire for general purposes.'

H.G. 14. T

H.G. 15 (Condition W or WP)

B.S. 1476 : 'Aluminium and aluminium alloy rods, bars and sections for general purposes.'

H.E. 11. WP

H.E. 14. T

H.E. 15 (Condition W or WP)

*For screws and bolts cold headed from wire :*

B.S. 1475 : 'Aluminium and aluminium alloy wire for general purposes.'

N.G. 6. M

H.G. 14. T

H.G. 15 (Condition W or WP)

**Dimensions.** The screws, bolts and nuts shall conform to the dimensions and tolerances given in the tables and the following clauses.

The screw heads shall be concentric with the shank. The slots shall be clean and free from burrs and, on visual inspection, shall appear to be closely co-incident with the centre line of the head.

NOTE. Screws and bolts turned from bars can be supplied with a smaller radius under the head if specially ordered.

**Length of screws and bolts.** *a. Countersunk heads.* The nominal length shall be the distance from the upper surface of the head to the extreme end of the shank, including any chamfer or radius.

*b. Raised-countersunk (instrument) heads.* The nominal length shall be the distance from the upper surface of the head (excluding the raised portion) to the extreme end of the shank, including any chamfer or radius.

*c. Hexagonal, round, cheese, raised-cheese (fillister), and connection heads.* The nominal length shall be the distance from the underside of the head to the extreme end of the shank, including any chamfer or radius.

## B.A. Screws, Bolts, Nuts and Washers

*d. Tolerance on length.* The permissible tolerance on the nominal length of screws and bolts shall be as follows :—

Nominal length	Tolerance
Up to and including $\frac{1}{8}$ in.	+ 0.01 in. — 0.
Above $\frac{1}{8}$ in., up to and including $\frac{1}{2}$ in.	+ 0.02 in. — 0.
Above $\frac{1}{2}$ in.	+ $\frac{1}{32}$ in. — 0.

**Ends of screws and bolts.** *a. Cut threads.* The ends of screws and bolts with cut threads may, at the option of the manufacturer, be finished with either a flat chamfer with a  $90^\circ$  included angle to a depth slightly exceeding the depth of thread, or with a radius approximately equal to  $1\frac{1}{4}$  times the nominal diameter of the shank.

*b. Rolled threads.* When screws and bolts are made with rolled threads the lead formed at the end of the screw or bolt by the thread-rolling operation may be regarded as providing the necessary chamfer to the end and no other machining operation is necessary, unless the purchaser, in his enquiry and order, has specified that the ends shall be finished as in *a* above.

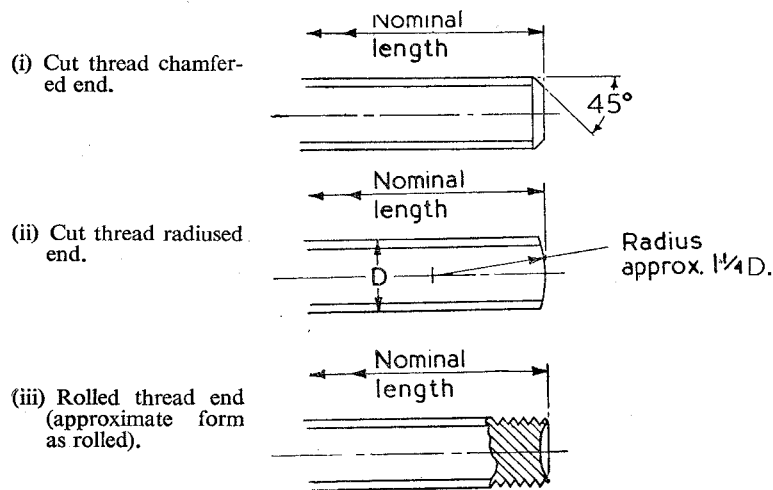

Alternative types of ends permissible on screws and bolts.

**Screw threads.** *a. Screws and bolts.* The screw threads may be either cut or rolled, at the option of the manufacturer. Limits and tolerances shall be as specified for normal class bolts in B.S. 93 : 1951, 'British Association screw threads.' Screws and bolts with close class threads are not normally stocked and should not be ordered, except for special work where refined accuracy of pitch and thread form is particularly required. If the limits and tolerances in respect of the screws and bolts are to be as specified for close class bolts in B.S. 93 : 1951, this shall be stated by the purchaser in his enquiry and order.

*b. Nuts.* The limits and tolerances of the screw threads shall be as specified in B.S. 93 : 1951.

**Length of thread on screws and bolts.** *a. Screws : countersunk and raised-countersunk heads.* These shall be threaded right up to the head.

*b. Screws : hexagonal, round, cheese, raised-cheese (fillister) and connection heads.* These shall be threaded to leave a limited length of unthreaded shank under the head. The length of unthreaded shank is defined as the distance from the leading face of a nut which has been screwed as far as possible on to the screw by hand to the underside of the head. The nut shall have threads as specified above and shall not be countersunk.

The length of unthreaded shank shall not exceed the following :—

Nominal length of screw	Length of unthreaded shank
Up to and including 5 times the diameter.	Not to exceed $1\frac{1}{2}$ times the pitch.
Greater than 5 times the diameter.	Not to exceed $2\frac{1}{2}$ times the pitch.

*c. Bolts.* The length of thread on bolts shall be the distance from the end of the bolt (including any chamfer or radius) to the leading face of a nut which has been screwed as far as possible on to the bolt by hand. The nut shall have threads as specified above and shall not be countersunk.

The length of thread shall be not less than three times the nominal diameter of the bolt.

**Chamfering and washer-facing.** *a. Hexagonal headed screws and bolts.* These shall have a chamfer of approximately  $30^\circ$  on their upper faces. The underside of the head may, at the option of the manufacturer, be finished flat, or in the case of sizes 0 to 6 B.A. inclusive, have a washer-face.

*b. Hexagonal ordinary (or full) nuts.* These shall have a chamfer of approximately  $30^\circ$  on both faces, but sizes 13 B.A. and smaller may, at the option of the manufacturer, be chamfered on one face only.

*c. Hexagonal thin (or lock) nuts.* These shall have a chamfer of approximately  $30^\circ$  on both faces.

## SECTION TWO : PLAIN WASHERS

This Section gives dimensions, shown in the tables, applicable to both ferrous and non-ferrous plain washers for use with Nos. 0 to 10 B.A. screws and bolts.

Two types of washers (large and small) are included for use with Nos. 0 to 8 B.A. screws and bolts and one type (large) for use with No. 9 and No. 10 B.A. screws and bolts.

**Designation.** The washers shall be designated by the B.A. number and the type of washer, namely, 'large,' or 'small,' e.g. '4 B.A. large.'

**Finish.** The washers shall be flat and free from burrs. They may, at the manufacturer's option, have a small chamfer on the outer edge of one face.

**Dimensions.** The washers shall conform to the dimensions and tolerances given in the Tables, as appropriate.

CHEESE HEAD SCREWS

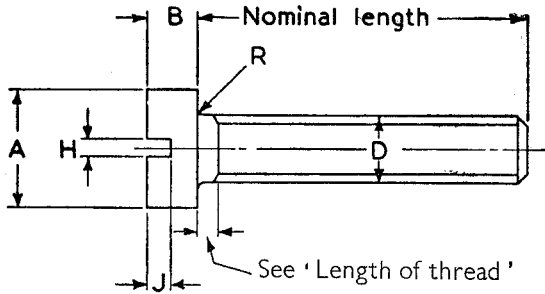

Cheese head screw

1	2	3	4	5	6	7	8	9	10	11	12
B.A. No.	Diameter of shank and major diameter of thread D		Diameter of head A		Depth of head B		Radius under head R	Slot			
	max.		max.	min.	max.	min.		Width H		Depth J	
		mm.	in.	in.	in.	in.	in.	in.	in.	in.	nom.
Preferred	2	4.7	0.185	0.319	0.309	0.130	0.123	0.015	0.052	0.044	0.058
	4	3.6	0.142	0.252	0.242	0.101	0.095	0.010	0.040	0.034	0.045
	6	2.8	0.110	0.194	0.184	0.078	0.073	0.010	0.033	0.027	0.035
	8	2.2	0.087	0.157	0.147	0.063	0.059	0.010	0.030	0.024	0.027
	10	1.7	0.067	0.112	0.107	0.045	0.041	0.007	0.024	0.019	0.020
	12	1.3	0.051	0.095	0.090	0.038	0.035	0.005	0.020	0.015	0.017
Second choice	0*	6.0	0.236	0.413	0.403	0.167	0.159	0.015	0.064	0.056	0.075
	1	5.3	0.209	0.366	0.356	0.148	0.141	0.015	0.058	0.050	0.066
	3	4.1	0.161	0.283	0.273	0.113	0.107	0.015	0.047	0.039	0.051
	5	3.2	0.126	0.221	0.211	0.088	0.083	0.010	0.040	0.034	0.040
Not normally stocked	7	2.5	0.098	0.173	0.163	0.069	0.064	0.010	0.033	0.027	0.031
	9	1.9	0.075	0.128	0.123	0.052	0.048	0.007	0.030	0.024	0.024
	11	1.5	0.059	0.110	0.105	0.045	0.041	0.005	0.024	0.019	0.020
	13	1.2	0.047	0.081	0.076	0.032	0.029	0.005	0.020	0.015	0.014
	14	1.0	0.039	0.064	0.059	0.026	0.023	0.003	0.015	0.011	0.012
	15	0.9	0.035	0.064	0.059	0.026	0.023	0.003	0.015	0.011	0.012
16	0.79	0.031	0.058	0.054	0.023	0.020	0.003	0.013	0.009	0.010	

\* It is recommended that 1/4 in. B.S.F. screws to B.S. 450, 'Bright countersunk, round and cheese head screws (B.S.W. and B.S.F.),' be used in preference to 0 B.A.

NOTE. If the slot is produced by plunge milling, dimension J is measured from the upper surface of the head to the point at which the slot breaks out on the surface of the head.

ROUND HEAD SCREWS

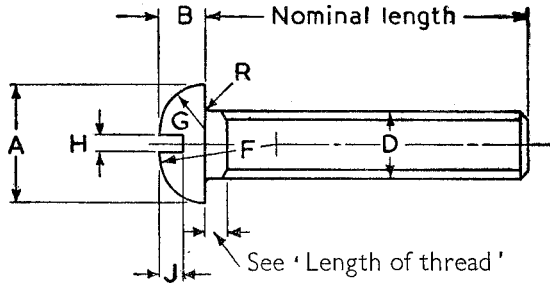

Round head screw

1	2	3	4	5	6	7	8	9	10	11	12	13
B.A. No.		Diameter of shank and major diameter of thread D		Diameter of head A		Depth of head B		Radius under head R	Radius of head F	Slot		
				max.	min.	max.	min.	max.	approx.	max.	min.	nom.
		mm.	in.	in.	in.	in.	in.	in.	in.	in.	in.	in.
Preferred	2	4.7	0.185	0.319	0.309	0.130	0.123	0.015	0.319	0.052	0.044	0.071
	4	3.6	0.142	0.252	0.242	0.101	0.095	0.010	0.252	0.040	0.034	0.056
	6	2.8	0.110	0.194	0.184	0.078	0.073	0.010	0.194	0.033	0.027	0.043
	8	2.2	0.087	0.157	0.147	0.063	0.059	0.010	0.157	0.030	0.024	0.035
	10	1.7	0.067	0.112	0.107	0.045	0.041	0.007	0.112	0.024	0.019	0.025
Second choice	0*	6.0	0.236	0.413	0.403	0.167	0.159	0.015	0.413	0.064	0.056	0.092
	1	5.3	0.209	0.366	0.356	0.148	0.141	0.015	0.366	0.058	0.050	0.081
	3	4.1	0.161	0.283	0.273	0.113	0.107	0.015	0.283	0.047	0.039	0.062
	5	3.2	0.126	0.221	0.211	0.088	0.083	0.010	0.221	0.040	0.034	0.048
Not normally stocked	7	2.5	0.098	0.173	0.163	0.069	0.064	0.010	0.173	0.033	0.027	0.038
	9	1.9	0.075	0.128	0.123	0.052	0.048	0.007	0.128	0.030	0.024	0.029
	11	1.5	0.059	0.110	0.105	0.045	0.041	0.005	0.110	0.024	0.019	0.025
	12	1.3	0.051	0.095	0.090	0.038	0.035	0.005	0.095	0.020	0.015	0.021
	13	1.2	0.047	0.081	0.076	0.032	0.029	0.005	0.081	0.020	0.015	0.018
	14	1.0	0.039	0.064	0.059	0.026	0.023	0.003	0.064	0.015	0.011	0.014
	15	0.9	0.035	0.064	0.059	0.026	0.023	0.003	0.064	0.015	0.011	0.014
	16	0.79	0.031	0.058	0.054	0.023	0.020	0.003	0.058	0.013	0.009	0.013

\* It is recommended that 1/4 in. B.S.F. screws to B.S. 450, 'Bright countersunk, round and cheese head screws (B.S.W. and B.S.F.),' be used in preference to 0 B.A.

NOTE 1. If the slot is produced by plunge milling, dimension J is measured from the upper surface of the head to the point at which the slot breaks out on the surface of the head.

NOTE 2. Shape of head. The shape of the head shall closely approximate to a half-ellipse. Radius G (struck off the underside of the head) must pass through diameter A and touch radius F.

COUNTERSUNK HEAD SCREWS

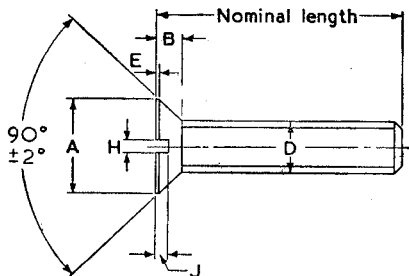

Countersunk head screw

1	2	3	4	5	6	7	8	9	10	11
B.A. No.	Major diameter of thread		Diameter of head		Depth of head		Slot			
	D		A		Total B	E	Width H		Depth J	
	max.		max.	min.	nom.	max.	max.	min.	nom.	
		mm.	in.	in.	in.	in.	in.	in.	in.	in.
Preferred	2	4.7	0.185	0.319	0.309	0.077	0.010	0.052	0.044	0.036
	4	3.6	0.142	0.252	0.242	0.065	0.010	0.040	0.034	0.031
	6	2.8	0.110	0.194	0.184	0.051	0.009	0.033	0.027	0.024
	8	2.2	0.087	0.157	0.147	0.043	0.008	0.030	0.024	0.021
	10	1.7	0.067	0.112	0.107	0.030	0.007	0.024	0.019	0.016
	12	1.3	0.051	0.095	0.090	0.028	0.006	0.020	0.015	0.014
Second choice	0*	6.0	0.236	0.413	0.403	0.099	0.010	0.064	0.056	0.045
	1	5.3	0.209	0.366	0.356	0.089	0.010	0.058	0.050	0.041
	3	4.1	0.161	0.283	0.273	0.071	0.010	0.047	0.039	0.033
	5	3.2	0.126	0.221	0.211	0.058	0.010	0.040	0.034	0.028
Not normally stocked	7	2.5	0.098	0.173	0.163	0.047	0.009	0.033	0.027	0.023
	9	1.9	0.075	0.128	0.123	0.035	0.008	0.030	0.024	0.018
	11	1.5	0.059	0.110	0.105	0.033	0.007	0.024	0.019	0.016
	13	1.2	0.047	0.081	0.076	0.023	0.006	0.020	0.015	0.012
	14	1.0	0.039	0.064	0.059	0.019	0.006	0.015	0.011	0.011
	15	0.9	0.035	0.064	0.059	0.021	0.006	0.015	0.011	0.011
	16	0.79	0.031	0.058	0.054	0.019	0.005	0.013	0.009	0.010

\* It is recommended that 1/4 in. B.S.F. screws to B.S. 450, 'Bright countersunk, round and cheese head screws (B.S.W. and B.S.F.)' be used in preference to 0 B.A.

NOTE. If the slot is produced by plunge milling, dimension J is measured from the upper surface of the head to the point at which the slot breaks out on the surface of the head.

RAISED-COUNTERSUNK (INSTRUMENT) HEAD SCREWS

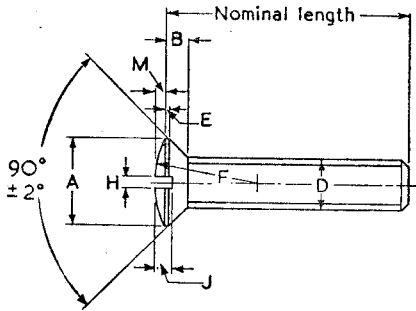

Raised-countersunk head screw

1	2	3	4	5	6	7	8	9	10	11	12	13
B.A. No.	Major diameter of thread		Diameter of head		Depth of head			Radius	Slot			
	D		A		E	B	M		F	Width H		Depth J
	max.		max.	min.	max.	nom.	approx.	nom.	max.	min.	nom.	
	mm.	in.	in.	in.	in.	in.	in.	in.	in.	in.	in.	in.
Preferred	2	4.7	0.185	0.319	0.309	0.010	0.077	0.036	0.370	0.052	0.044	0.059
	4	3.6	0.142	0.252	0.242	0.010	0.065	0.029	0.283	0.040	0.034	0.049
	6	2.8	0.110	0.194	0.184	0.009	0.051	0.023	0.220	0.033	0.027	0.039
	8	2.2	0.087	0.157	0.147	0.008	0.043	0.019	0.173	0.030	0.024	0.033
	10	1.7	0.067	0.112	0.107	0.007	0.030	0.013	0.134	0.024	0.019	0.024
Not normally stocked	0*	6.0	0.236	0.413	0.403	0.010	0.099	0.048	0.472	0.064	0.056	0.075
	1	5.3	0.209	0.366	0.356	0.010	0.089	0.042	0.417	0.058	0.050	0.067
	3	4.1	0.161	0.283	0.273	0.010	0.071	0.035	0.323	0.047	0.039	0.056
	5	3.2	0.126	0.221	0.211	0.010	0.058	0.026	0.252	0.040	0.034	0.045
	7	2.5	0.098	0.173	0.163	0.009	0.047	0.022	0.197	0.033	0.027	0.037
	9	1.9	0.075	0.128	0.123	0.008	0.035	0.014	0.150	0.030	0.024	0.027
	11	1.5	0.059	0.110	0.105	0.007	0.033	0.013	0.118	0.024	0.019	0.024
	12	1.3	0.051	0.095	0.090	0.006	0.028	0.012	0.102	0.020	0.015	0.022
	13	1.2	0.047	0.081	0.076	0.006	0.023	0.009	0.094	0.020	0.015	0.018
	14	1.0	0.039	0.064	0.059	0.006	0.019	0.008	0.079	0.015	0.011	0.016
	15	0.9	0.035	0.064	0.059	0.006	0.021	0.008	0.071	0.015	0.011	0.016
16	0.79	0.031	0.058	0.054	0.005	0.019	0.006	0.062	0.013	0.009	0.013	

\* It is recommended that 1/4 in. B.S.F. screws (which will be included in the revised B.S. 450) be used in preference to 0 B.A.

NOTE. If the slot is produced by plunge milling, dimension J is measured from the upper surface of the head to the point at which the slot breaks out on the surface of the head.

HEXAGONAL HEADED SCREWS AND BOLTS

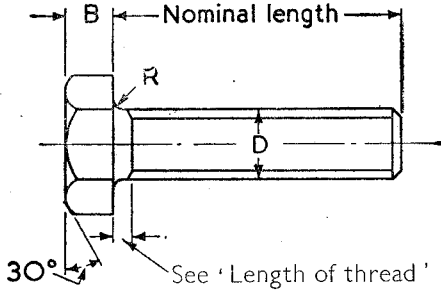

Hexagonal headed screw

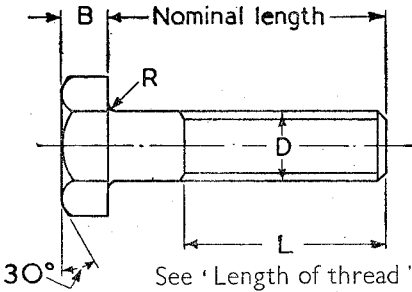
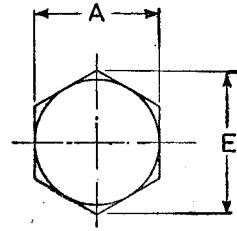

Hexagonal headed bolt

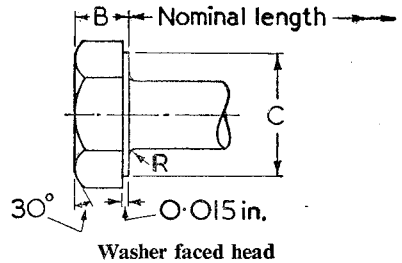

Washer faced head

B.A. No.		Diameter of shank and major diameter of thread D		Width across flats A		Width across corners E	Thickness of head B		Radius under head R	Diameter of washer face C'		Length of thread of bolts L
		max.	min.	max.	min.	max.	min.	max.	min.	max.	min.	
		mm.	in.	in.	in.	in.	in.	in.	in.	in.	in.	
Preferred	2	4.7	0.185	0.324	0.319	0.37	0.139	0.132	0.015	0.319	0.309	0.55
	4	3.6	0.142	0.248	0.243	0.29	0.106	0.100	0.010	0.243	0.233	0.43
Not normally stocked	0*	6.0	0.236	0.413	0.408	0.48	0.177	0.169	0.015	0.408	0.398	0.71
	1	5.3	0.209	0.365	0.360	0.42	0.156	0.149	0.015	0.360	0.350	0.63
	3	4.1	0.161	0.282	0.277	0.33	0.121	0.115	0.015	0.277	0.267	0.48
	5	3.2	0.126	0.220	0.216	0.25	0.094	0.089	0.010	0.216	0.206	0.38
	6	2.8	0.110	0.193	0.189	0.22	0.083	0.078	0.010	0.189	0.179	0.33
	7	2.5	0.098	0.172	0.169	0.20	0.074	0.070	0.010	—	—	0.29
	8	2.2	0.087	0.152	0.149	0.18	0.065	0.061	0.010	—	—	0.26
	9	1.9	0.075	0.131	0.128	0.15	0.056	0.052	0.007	—	—	0.22
	10	1.7	0.067	0.117	0.114	0.14	0.050	0.046	0.007	—	—	0.20

\* It is recommended that 1/4 in. B.S.F. screws and bolts to B.S. 1083, 'Precision hexagon bolts, screws, nuts (B.S.W. and B.S.F. threads) and plain washers,' be used in preference to 0 B.A.



HEXAGONAL ORDINARY (OR FULL) NUTS AND THIN (OR LOCK) NUTS

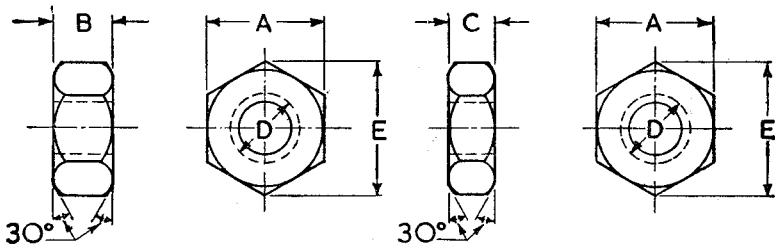

Hexagonal ordinary nut

Hexagonal thin (or lock) nut

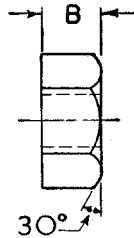

Hexagonal ordinary nut

Alternative chamfering permissible on sizes 13 B.A. and smaller.

1	2	3	4	5	6	7	8	9	10	11											
											B.A. No.	Nominal diameter of thread D		Width across flats A		Width across corners E	Thickness				
														max.	min.	max.	Ordinary (or full) nuts B		Thin (or lock) nuts C		
Preferred	2	4.7	0.185	0.324	0.319	0.37	0.167	0.157	0.123	0.113											
	4	3.6	0.142	0.248	0.243	0.29	0.135	0.125	0.094	0.084											
	6	2.8	0.110	0.193	0.189	0.22	0.105	0.095	0.073	0.063											
	8	2.2	0.087	0.152	0.149	0.18	0.082	0.075	0.058	0.051											
	10	1.7	0.067	0.117	0.114	0.14	0.064	0.057	—	—											
	12	1.3	0.051	0.090	0.088	0.10	0.049	0.044	—	—											
Second choice	0*	6.0	0.236	0.413	0.408	0.48	0.213	0.203	0.157	0.147											
	1	5.3	0.209	0.365	0.360	0.42	0.188	0.178	0.139	0.129											
	3	4.1	0.161	0.282	0.277	0.33	0.153	0.143	0.108	0.098											
	5	3.2	0.126	0.220	0.216	0.25	0.120	0.110	0.084	0.074											
Not normally stocked	7	2.5	0.098	0.172	0.169	0.20	0.094	0.087	—	—											
	9	1.9	0.075	0.131	0.128	0.15	0.071	0.064	—	—											
	11	1.5	0.059	0.103	0.101	0.12	0.056	0.051	—	—											
	13	1.2	0.047	0.083	0.081	0.10	0.045	0.040	—	—											
	14	1.0	0.039	0.069	0.067	0.08	0.037	0.032	—	—											
	15	0.9	0.035	0.062	0.060	0.07	0.034	0.029	—	—											
	16	0.79	0.031	0.056	0.054	0.07	0.029	0.024	—	—											

\* It is recommended that 1/4 in. B.S.F. nuts to B.S. 1083, 'Precision hexagon bolts, screws, nuts (B.S.W. and B.S.F. threads) and plain washers,' be used in preference to O.B.A.

LARGE PLAIN WASHERS

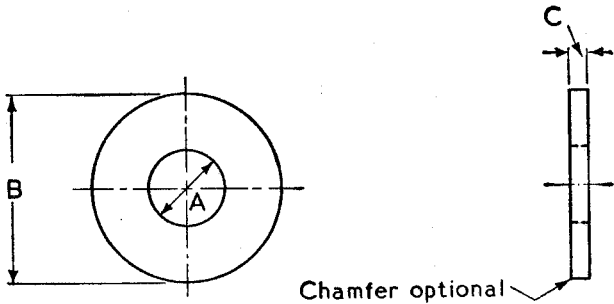

1	2	3	4	5	6	7	
B.A. No.		Diameter of hole A		Outside diameter B		Thickness C	
		max.	min.	max.	min.	S.W.G.	(in.)
		in.	in.	in.	in.		
Preferred	2	0.202	0.197	0.500	0.495	18	(0.048)
	4	0.157	0.152	0.378	0.373	19	(0.040)
	6	0.123	0.118	0.288	0.283	20	(0.036)
	8	0.099	0.094	0.228	0.223	25	(0.020)
	10	0.078	0.073	0.176	0.171	27	(0.016)
Second choice	0	0.256	0.251	0.625	0.620	17	(0.056)
	1	0.228	0.223	0.565	0.560	18	(0.048)
	3	0.177	0.172	0.432	0.427	19	(0.040)
	5	0.140	0.135	0.335	0.330	20	(0.036)
Not normally stocked	7	0.111	0.106	0.257	0.252	22	(0.028)
	9	0.086	0.081	0.197	0.192	27	(0.016)

NOTE. The dimensions given in Col. 7 for the thickness of the washers shall be subject to the normal manufacturing tolerances on the sheet or strip.

SMALL PLAIN WASHERS

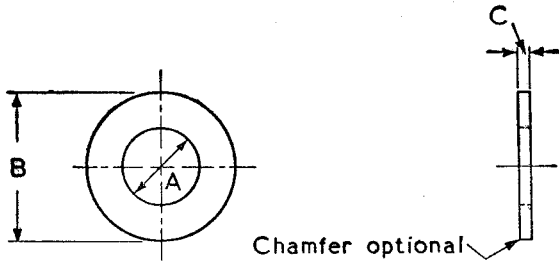

1	2	3	4	5	6	7	
B.A. No.	Diameter of hole A		Outside diameter B		Thickness C		
	max.	min.	max.	min.	S.W.G.	(in.)	
	in.	in.	in.	in.			
Preferred	2	0.202	0.197	0.391	0.386	21	(0.032)
	4	0.157	0.152	0.301	0.296	22	(0.028)
	6	0.123	0.118	0.233	0.228	23	(0.024)
	8	0.099	0.094	0.185	0.180	25	(0.020)
Second choice	0	0.256	0.251	0.500	0.495	19	(0.040)
	1	0.228	0.223	0.443	0.438	20	(0.036)
	3	0.177	0.172	0.341	0.336	22	(0.028)
	5	0.140	0.135	0.268	0.263	23	(0.024)
Not normally stocked	7	0.111	0.106	0.208	0.203	24	(0.022)

NOTE. The dimensions given in Col. 7 for the thickness of the washers shall be subject to the normal manufacturing tolerances on the sheet or strip.

**SPECIAL TYPES OF SCREWS NOT NORMALLY STOCKED**  
**RAISED CHEESE (FILLISTER) HEAD SCREWS**

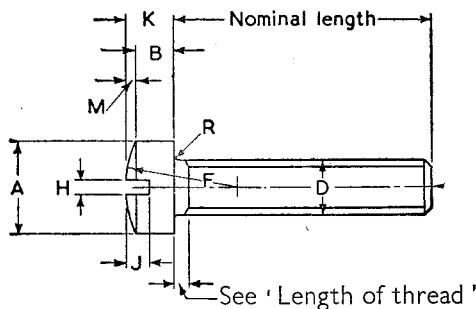

**Raised cheese (fillister) head screw**

1	2		3		4		5		6		7		8		9		10		11		12		13		14	
	B.A. No.	Diameter of shank and major diameter of thread		Diameter of head		Depth of head				Radius	Radius under head	Slot														
		D		A		B	M	Total depth K				F	R	Width H		Depth J										
		max.	max.	min.	nom.	approx.	max.	min.	nom.	max.	max.	min.	nom.	max.	min.	nom.										
	mm.	in.	in.	in.	in.	in.	in.	in.	in.	in.	in.	in.	in.	in.	in.	in.	in.	in.	in.	in.	in.	in.	in.	in.	in.	
0	6.0	0.236	0.413	0.403	0.163	0.048	0.215	0.207	0.472	0.015	0.064	0.056	0.107													
1	5.3	0.209	0.366	0.356	0.144	0.042	0.189	0.182	0.417	0.015	0.058	0.050	0.094													
2	4.7	0.185	0.319	0.309	0.126	0.036	0.165	0.158	0.370	0.015	0.052	0.044	0.082													
3	4.1	0.161	0.283	0.273	0.111	0.035	0.149	0.143	0.323	0.015	0.047	0.039	0.074													
4	3.6	0.142	0.252	0.242	0.099	0.029	0.131	0.125	0.283	0.010	0.040	0.034	0.065													
5	3.2	0.126	0.221	0.211	0.086	0.026	0.114	0.109	0.252	0.010	0.040	0.034	0.057													
6	2.8	0.110	0.194	0.184	0.076	0.023	0.101	0.096	0.220	0.010	0.033	0.027	0.050													
7	2.5	0.098	0.173	0.163	0.067	0.022	0.091	0.086	0.197	0.010	0.033	0.027	0.045													
8	2.2	0.087	0.157	0.147	0.061	0.019	0.082	0.078	0.173	0.010	0.030	0.024	0.041													
9	1.9	0.075	0.128	0.123	0.050	0.014	0.066	0.062	0.150	0.007	0.030	0.024	0.033													
10	1.7	0.067	0.112	0.107	0.043	0.013	0.058	0.054	0.134	0.007	0.024	0.019	0.029													
11	1.5	0.059	0.110	0.105	0.043	0.013	0.058	0.054	0.118	0.005	0.024	0.019	0.029													
12	1.3	0.051	0.095	0.090	0.037	0.012	0.050	0.047	0.102	0.005	0.020	0.015	0.025													
13	1.2	0.047	0.081	0.076	0.031	0.009	0.041	0.038	0.094	0.005	0.020	0.015	0.020													
14	1.0	0.039	0.064	0.059	0.025	0.008	0.034	0.031	0.079	0.003	0.015	0.011	0.017													
15	0.9	0.035	0.064	0.059	0.025	0.008	0.034	0.031	0.071	0.003	0.015	0.011	0.017													
16	0.79	0.031	0.058	0.054	0.022	0.006	0.029	0.026	0.062	0.003	0.013	0.009	0.014													

NOTE. If the slot is produced by plunge milling, dimension J is measured from the upper surface of the head to the point at which the slot breaks out on the surface of the head.

CONNECTION HEAD SCREWS

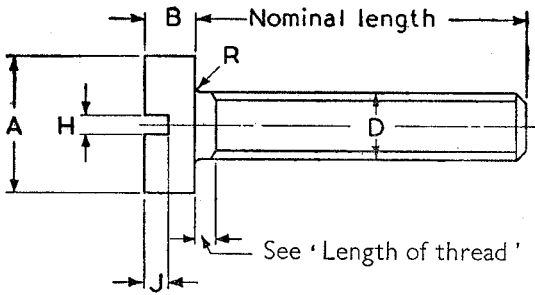

Connection head screw

B.A. No.	Diameter of shank and major diameter of thread D		Diameter of head A		Depth of head B		Radius under head R	Slot		
	max.		max.	min.	max.	min.		Width H		Depth J
	mm.	in.	in.	in.	in.	in.	in.	in.	in.	in.
0	6.0	0.236	0.473	0.463	0.168	0.160	0.015	0.064	0.056	0.075
1	5.3	0.209	0.413	0.403	0.146	0.139	0.015	0.058	0.050	0.066
2	4.7	0.185	0.366	0.356	0.130	0.123	0.015	0.052	0.044	0.058
3	4.1	0.161	0.319	0.309	0.113	0.107	0.015	0.047	0.039	0.051
4	3.6	0.142	0.283	0.273	0.100	0.094	0.010	0.040	0.034	0.045
5	3.2	0.126	0.252	0.242	0.088	0.083	0.010	0.040	0.034	0.040
6	2.8	0.110	0.221	0.211	0.078	0.073	0.010	0.033	0.027	0.035
7	2.5	0.098	0.194	0.184	0.068	0.064	0.010	0.033	0.027	0.031
8	2.2	0.087	0.173	0.163	0.061	0.057	0.010	0.030	0.024	0.027
9	1.9	0.075	0.157	0.147	0.055	0.051	0.007	0.030	0.024	0.024
10	1.7	0.067	0.128	0.123	0.046	0.042	0.007	0.024	0.019	0.020
11	1.5	0.059	0.110	0.105	0.039	0.036	0.005	0.024	0.019	0.020
12	1.3	0.051	0.110	0.105	0.039	0.036	0.005	0.020	0.015	0.017
13	1.2	0.047	0.095	0.090	0.033	0.030	0.005	0.020	0.015	0.014
14	1.0	0.039	0.081	0.076	0.028	0.025	0.003	0.015	0.011	0.012
15	0.9	0.035	0.064	0.059	0.023	0.020	0.003	0.015	0.011	0.012
16	0.79	0.031	0.064	0.059	0.023	0.020	0.003	0.013	0.009	0.010

NOTE. If the slot is produced by plunge milling, dimension J is measured from the upper surface of the head to the point at which the slot breaks out on the surface of the head.

APPROXIMATE PROPORTIONS

SCREWS

Type of screw	Diameter of head (max.)	Depth of head (max.)
Cheese head screw	Based on the rule $A=1.75D$ ; but the dimensions have been adjusted slightly so that they come within the diameters of available round bars to B.S. limits.	0.7D
Round head screw		0.7D
Countersunk head screw		0.45D
Raised countersunk (instrument) head screw		Countersunk portion = 0.45D Total depth = 0.65D
Raised cheese (fillister) head screw		Cylindrical portion = 0.7D Total depth = 0.9D
Connection head screw	Based on 2D, but see note above.	0.7D

HEXAGONAL SCREW AND BOLT HEADS AND NUTS

	Width across flats (max.)	Thickness (max.)
Screws and bolts	1.75D	0.75D
Ordinary (or full) nuts	1.75D	0, 1, and 2 B.A. = 0.9D 3 B.A. and smaller = 0.95D
Thin (or lock) nuts	1.75D	2/3D

WASHERS

	Outside diameter (max.)
Large washers	2.65D
Small washers	2.12D