

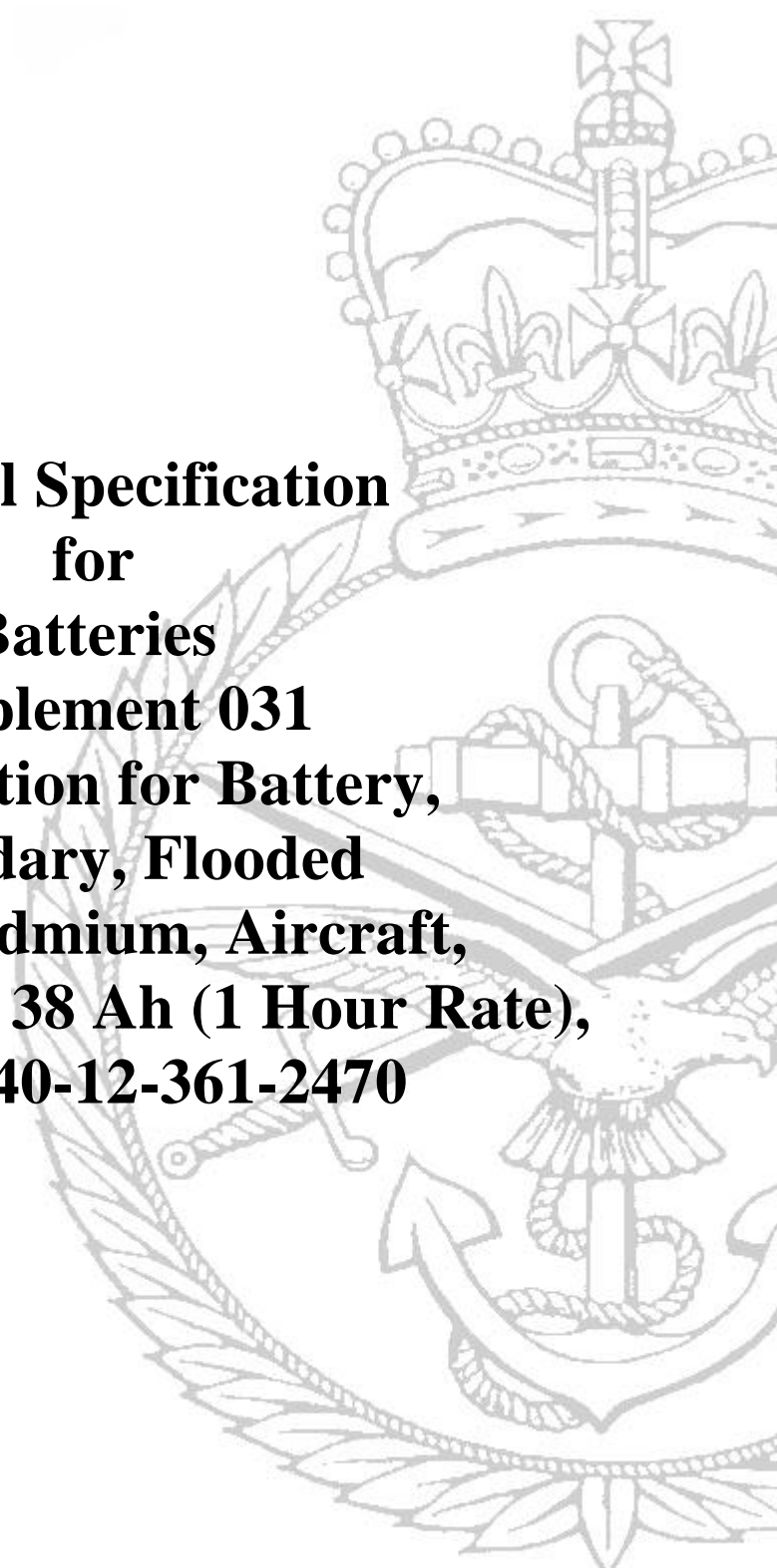

# Ministry of Defence Defence Standard 61-21

Issue 1 Publication Date 29 October 2004



**General Specification  
for  
Batteries  
Supplement 031  
Specification for Battery,  
Secondary, Flooded  
Nickel-Cadmium, Aircraft,  
Aerobatic 24V 38 Ah (1 Hour Rate),  
NSN 6140-12-361-2470**

**AMENDMENT RECORD**

<b>Amd No</b>	<b>Date</b>	<b>Text Affected</b>	<b>Signature and Date</b>

CONTENT

<b>Description</b>	<b>Page</b>
Content	1
Preface	2
Main Text	3
 <b>SECTION 1 GENERAL REQUIREMENTS</b>	
<b>0</b> Introduction	4
<b>1</b> Scope	4
<b>2</b> Warning	4
<b>3</b> Related Documents	5
<b>4</b> Definitions	5
<b>5</b> Abbreviations	5
 <b>SECTION 2 ELECTRICAL CHARACTERISTICS</b>	
<b>6</b> Electrochemical System	6
<b>7</b> Nominal Voltage	6
 <b>SECTION 3 PHYSICAL CHARACTERISTICS</b>	
<b>8</b> Materials and Construction	7
<b>9</b> Identification	7
<b>10</b> Dimensions	7
<b>11</b> Mass	7
<b>12</b> Temperature Range	8
 <b>SECTION 4 PERFORMANCE REQUIREMENTS</b>	
<b>13</b> General Test Conditions	9
<b>14</b> Commissioning Procedure	9
<b>15</b> Battery Charging	9
<b>16</b> Electrical Testing	10
<b>17</b> Environmental Testing	15

CONTENT

<b>Description</b>	<b>Page</b>
<b>SECTION 5    PRODUCT CONFORMITY CERTIFICATION</b>	
<b>18</b> General Requirements	19
<b>19</b> Product Conformity Test Requirement	19
<b>20</b> Hazard Classification and Transportation Requirements	23
<b>SECTION 6    MARKING REQUIREMENTS</b>	
<b>21</b> Marking	24
<b>SECTION 7    PACKAGING AND LABELLING REQUIREMENTS</b>	
<b>22</b> General Requirements	25
<b>Figure 1</b>	20
<b>Figure 2</b>	21
<b>Table 1</b>	13
<b>Table 2</b>	22

**PREFACE**

**Standards for Defence**

**Specification for**

**Battery, Secondary, Flooded Nickel-Cadmium,  
Aircraft, Aerobatic**

**24V 38.0 Ah (1 Hour Rate)**

**NSN 6140-12-361-2470**

- a.** This supplement shall be read in conjunction with Def Stan 61-21.
- b.** This supplement provides a definitive specification for the electrical, physical, performance and nomenclature requirements for a 20-cell, 24V 38.0 Ah (Minimum) Flooded Nickel-Cadmium battery.
- c.** This supplement has been agreed by the authorities concerned with its use and is intended to be used whenever relevant in all future designs, contracts, orders etc. and whenever practicable by amendment to those already in existence. If any difficulty arises which prevents application of this Defence Standard and its associated supplements, the UK Defence Standardization (DStan) shall be informed so that a remedy may be sought.
- d.** Any enquiries regarding this standard in relation to an invitation to tender or a contract in which it is incorporated are to be addressed to the responsible technical or supervising authority named in the invitation to tender or contract.
- e.** Compliance with this Defence Standard shall not in itself relieve any person from any legal obligations imposed upon them.
- f.** This standard has been devised solely for the use of the Ministry of Defence (MOD) and its contractors in the execution of contracts for the MOD. To the extent permitted by law, the MOD hereby excludes all liability whatsoever and howsoever arising (including, but without limitation, liability resulting from negligence) for any loss or damage however caused when the standard is used for any other purpose.

**TEXT**

**Standards for Defence**

**Battery, Secondary, Flooded Nickel-Cadmium,  
Aircraft, Aerobatic**

**24V 38.0 Ah (1 Hour Rate)**

**NSN 6140-12-361-2470**

**SECTION 1 GENERAL REQUIREMENTS**

**0 INTRODUCTION**

It is Ministry of Defence (MOD) policy to purchase batteries against performance specifications whenever possible. Defence Standard 61-21 and its series of supplements has been generated to address the current requirements for batteries. This supplement is applicable when invoked directly by a MOD invitation to tender, contract, or when referred to by other MOD battery specifications.

**1 SCOPE**

This supplement provides a definitive specification for the electrical, physical, performance and nomenclature requirements for a 24V 38.0 Ah (Minimum) Flooded Nickel Cadmium battery, NSN 6140-12-361-2470. It is essential that the battery be operated only within its design and performance parameters. This supplement invokes Product Conformity Certification.

**2 WARNING**

The Ministry of Defence (MOD), like its contractors, is subject to both United Kingdom and European laws regarding Health and Safety at Work, without exemption. All Defence Standards either directly or indirectly invoke the use of processes and procedures that could be injurious to health if adequate precautions are not taken. Defence Standards or their use in no way absolves users from complying with statutory and legal requirements relating to Health and Safety at Work.

## SECTION 1 GENERAL REQUIREMENTS

### 3 RELATED DOCUMENTS

**3.1** For the purposes of this supplement all related documents, with the exception of the following, are listed in Defence Standard 61-21.

- a) Def Stan 05-123 latest issue
- b) Def Stan 00-35 latest issue
- c) BS 3G 205 1983
- d) RTCA/DO-160D

**3.2** Reference in this standard to any related document means in any invitation to tender or contract the edition and all amendments current at the date of such tender or contract unless a specific edition is indicated.

**3.3** In consideration of **3.2** above, users shall be fully aware of the issue and amendment status of all related documents, particularly when forming part of an invitation to tender or contract. Responsibility for the correct application of standards rests with users.

**3.4** DStan can advise regarding where related documents are obtained from. Requests for such information can be made to the DStan Helpdesk. How to contact the helpdesk is shown on the outside rear cover of Defence Standards.

### 4 DEFINITIONS

Def Stan 61-21 definitions shall apply.

### 5 ABBREVIATIONS

Def Stan 61-21 abbreviations shall apply.

**SECTION 2 ELECTRICAL CHARACTERISTICS**

**6 ELECTROCHEMICAL SYSTEM**

The electrochemical system shall be flooded Nickel-Cadmium – stipulated as the ‘Battery-wet’ definition contained within Def Stan 61-21.

**7 NOMINAL VOLTAGE/CAPACITY**

The battery, consisting of 20-cells, shall have a nominal voltage of 24V, and have a 1-hour rated capacity of 38 Ah. The cells are to be numbered sequentially following the electrical path from the positive terminal to the negative terminal of the two-pole MS 3509 connector.



## SECTION 3 PHYSICAL CHARACTERISTICS

### 8 MATERIALS AND CONSTRUCTION

The battery shall comply generally with the requirements of BS 3G 205 1983; except that where differences occur, this particular specification shall apply.

The battery shall meet the Technical Procedure Requirement of the latest issue of Def-Stan 05-123 where applicable.

Reference to the manufacturing data package (build standard) of the battery shall be declared for materials, piece parts and processes used in the battery construction.

Lifting of the battery shall be of an appropriate method to prevent any damage to the battery or injury to personnel.

Venting of the battery shall be by scavenging airflow.

The battery shall be suitable for use in aerobatic and rotary wing aircraft.

The battery is not fitted with any means of temperature monitoring.

### 9 IDENTIFICATION

- a) Type of battery (nickel cadmium, aerobatic)
- b) NATO Stock Number
- c) Manufacturers name or identification
- d) Manufacturers type or part number
- e) Manufacturers serial number
- f) Date of manufacture
- g) Modifications incorporated
- h) Positive terminal polarity
- i) Nominal battery voltage and number of cells
- j) Nominal capacity

The battery shall not incorporate any items coloured pink which would cause confusion with regards to lead acid batteries (normally pink).

### 10 DIMENSIONS

The battery shall meet the overall dimensional requirements of **Figure 1**

### 11 MASS

The mass of the battery when correctly filled in accordance with the manufacturer's instructions shall be a maximum of 34.5 Kg.

**SECTION 3 PHYSICAL CHARACTERISTICS**

**12 TEMPERATURE RANGE**

The battery operational temperature range shall be  $-26^{\circ}\text{C}$  to  $+45^{\circ}\text{C}$  as demonstrated by the tests contained within this supplement.

The battery shall be stored in an ambient temperature of  $20 \pm 10^{\circ}\text{C}$  and a relative humidity between 45% and 75%.

## **SECTION 4 PERFORMANCE REQUIREMENTS**

### **13 GENERAL TEST CONDITONS**

These will apply unless otherwise stated.

#### **13.1 Laboratory Conditions**

The laboratory temperature and humidity shall be  $23^{\circ}\text{C} \pm 2^{\circ}\text{C}$  and between 35% and 70% respectively.

#### **13.2 Temperature Acclimatisation**

Where testing is to be performed at a temperature other than the ambient temperature of  $23^{\circ}\text{C} \pm 2^{\circ}\text{C}$ , batteries shall be conditioned at the specified test temperature for a period of 16-24 hours prior to test or recharging.

#### **13.3 Accuracy Of Measuring Equipment**

The measuring equipment used for the test shall have at least the following degree of accuracy.

- Voltage measurement shall be made to an accuracy of  $\pm 0.5\%$
- Current measurement shall be made to an accuracy of  $\pm 0.5\%$ .
- Thermometers shall have a maximum calibration error of  $\pm 1^{\circ}\text{C}$
- Time measurement shall be to a minimum accuracy of 0.5%

The range of the measuring equipment shall be compatible with the values being measured.

### **14 COMMISSIONING PROCEDURE**

Prior to undertaking the qualification exercise, the batteries shall be commissioned in accordance with the manufacturer's instructions.

### **15 BATTERY CHARGING**

- a) Once charged in accordance with the manufacturers instruction, unless specified herein, temperature stabilise the battery as follows:
- b) Prior to discharging, the battery shall stand on open circuit for a period of not less than 16 hours and no more than 24 hours at the test temperature specified, and shall be maintained within  $\pm 2^{\circ}\text{C}$ . During all discharges, the ambient temperature shall be maintained within  $\pm 2^{\circ}\text{C}$  of the test temperature.

## SECTION 4 PERFORMANCE REQUIREMENTS

*Note 1. During assessment to this specification, the battery may be given a normal service at the test temperature change points which shall include cleaning and charging ie, standard charging procedure with subsequent electrolyte-level maintenance.*

*Note 2. Prior to recharge following any high rate or low temperature discharge, the battery must be restored to  $23 \pm 2^{\circ}\text{C}$  by storing at this temperature for a period of 16-24 hours (see **section 13.3**) and residual capacity removed using a  $38 \pm 0.4$ amp discharge to an end point of 20 volts minimum.*

### 16 ELECTRICAL TESTING

#### 16.1 Rated Capacity

- a) The battery shall be charged and prepared as detailed in **section 15**.
- b) The battery shall then be discharged at 38 amps  $\pm 0.4$  at  $23 \pm 2^{\circ}\text{C}$  to a battery end voltage of 20V.
- c) The battery shall give a minimum duration of 1 hour.

#### 16.2 Capacity at low temperature

- a) The battery shall be charged and prepared as detailed in **section 15**, and then left on open circuit for a period of not less than 16 hours and not more than 24 hours at a temperature of  $-40^{\circ}\text{C} \pm 2^{\circ}\text{C}$ .
- b) The battery shall then be discharged at 38 amps  $\pm 0.4$  at  $-40 \pm 2^{\circ}\text{C}$  to a battery end voltage of 20V.
- c) The duration to the end-point voltage shall be declared.

#### 16.3 Insulation Resistance

- a) The insulation resistance shall be measured by applying 250V DC between the negative terminal and the case immediately after charge without cleaning.
- b) Clean the battery and re-measure the insulation resistance.
- c) The insulation resistance shall be greater than 250K ohms without cleaning and greater than 10M ohms after cleaning.

#### 16.4 Charge Retention

- a) The battery shall be charged and prepared as detailed in **section 15** and then it shall stand on open circuit for 28 days at an ambient temperature of  $23 \pm 2^{\circ}\text{C}$ .
- b) The battery shall then be discharged at 38amps  $\pm 0.4$
- c) The capacity obtained shall not be less than 80% of the rated capacity value obtained in **section 16.1**

## SECTION 4 PERFORMANCE REQUIREMENTS

### 16.5 Rapid Discharge Capacity

- a) The battery shall be charged and prepared as detailed in **section 15**.
- b) The battery shall then be discharged at 266amps  $\pm$  3amps (7 x C rate) at an ambient temperature of 23  $\pm$  2°C to a battery end voltage of 15.2 volts.
- c) The battery shall give a minimum duration of 5 minutes.

### 16.6 Low Temperature Starting Capability

- a) The battery shall be charged and prepared as detailed in **section 15**, and then left on open circuit for a period of not less than 16 hours and not more than 24 hours at a temperature of -18°C  $\pm$  2°C.
- b) The battery shall then be discharged at a current of 950 amps  $\pm$  10 amps (25 x C rate) for 10 seconds, followed immediately at a current of 380 amps  $\pm$  4amps (10 x C rate) for not less than 50 seconds.
- c) Throughout the 380amp, 50 second discharge period, the battery voltage shall not fall below 10V.

### 16.7 Life Test

- a) The battery shall be charged and prepared as detailed in **section 15**.
- b) The battery shall be discharged for a period of 4 hours at a constant current of 8 amps. The battery shall then be recharged for a period of 8 hours at a constant current of 5 amps,  $\pm$  10%. Two such cycles of discharge and charge are to be carried out every 24 hours.
- c) Following every 26th charge, the battery shall stand on open circuit for not less than 16 hours and not more than 24 hours at an ambient temperature of 23  $\pm$  2 °C. It shall then be discharged (27th discharge) at 38 amps  $\pm$  0.4amps to an end voltage of 20 volts (controlled discharged). If the duration of this discharge is not less than 48 minutes, the battery shall then be charged in accordance with **section 16** before resuming the life cycle test. If the duration is less than 48 minutes, the battery shall be serviced according to the manufacturer's instruction and then given an additional controlled discharge. If the duration of this discharge is not less than 48 minutes, the battery shall then resume the life testing.
- d) A controlled cycle of charge/discharge (defined above) shall also follow any life cycle where during the 4 hour discharge period, the on load voltage is less than 20V.
- e) The life of the battery is considered complete when two successive controlled discharges give less than 48 minutes
- f) The battery shall complete a minimum of 105 cycles (calculated as two less than the total completed).
- g) The battery shall then be subjected to the Capacity at Low Temperature test (**section 16.2** refers).

**SECTION 4 PERFORMANCE REQUIREMENTS**

**16.8 Internal Resistance**

- a) The battery shall be charged and prepared as detailed in **section 15** and then stabilised at each of the test temperatures for between 16 and 24 hours. The tests shall be performed at +25°C, -18°C and -40°C.
- b) A resistive load commencing at a value chosen to give an on load voltage of 13.2 volts ± 1 volt shall be stepped without a break in 5 sensibly spaced increments to value required to give an on load voltage of 20 volts ± 1 volt. The stepping shall be such that each load is applied for a period of 2.0 ± 0.1 seconds. The battery terminal voltage and current shall be measured at the end of each 2 second period.
- c) The internal resistance of the battery shall be determined by the slope of the tangent at the 16 volts plot of the battery terminal voltage versus current. Indicative values of internal resistance are shown below:

Test Temperature	Internal Resistance
25°C	10.4 milliohms
-18°C	15.9 milliohms
-40°C	46.6 milliohms

**16.9 Charge Acceptance**

- a) The battery shall initially be subjected to a rated capacity check (**section 16.1** refers).
- b) The battery shall then be recharged and prepared as detailed in **section 15** and then placed in a test chamber at 25 ± 2 °C. It shall then be discharged at 38amps ± 0.4amps for 45 minutes ± 0.5 and then be immediately charged at 27.0 volts ± 0.2V constant potential for 3 hours ± 5 minutes. The charging current shall be continuously recorded throughout this period.
- c) At the end of charge, the battery shall be discharged at 38 amps ± 0.4 amps to a battery end voltage of 20.0 volts. The battery shall then be tested using the identical procedure including the conditioning cycle as detailed in **section 16.9 (a)** according to the following test sequence.
- d) This sequence shall be repeated at a test temperature of 0°C.
- e) The overall sequence is shown in **Table 1**.

## SECTION 4 PERFORMANCE REQUIREMENTS

Charge Acceptance Test Sequence (unless stated, all charging according to manufacturer's instructions)		Ampere-hours removed	
		+25°C	0 °C
Recharge			
Discharge	38A to 20.00V end-point	≥ 38.0	≥ 38.0
Recharge			
Discharge	38A for 45 minutes (75% capacity removed)		
Recharge	27V constant-potential for 3 hours		
Discharge	38A to 20.00V end-point	≥ 21.5	≥ 14.5
Recharge			
Discharge	38A to 20.00V end-point		
Recharge			
Discharge	38A for 15 minutes (25% capacity removed)		
Recharge	27V constant-potential for 3 hours		
Discharge	38A to 20.00V end-point	≥ 31.9	≥ 29.4
Recharge			
Discharge	38A to 20.00V end-point		
Recharge			
Discharge	38A for 45 minutes (75% capacity removed)		
Recharge	28.5V constant-potential for 3 hours		
Discharge	38A to 20.00V end-point	≥ 35.3	≥ 31.3
Recharge			
Discharge	38A to 20.00V end-point		
Recharge			
Discharge	38A for 15 minutes (25% capacity removed)		
Recharge	28.5V constant-potential for 3 hours		
Discharge	38A to 20.00V end-point	≥ 37.3	≥ 32.5

Table 1. Charge Acceptance Test Sequence

## 16.10 Charge Stability

- The test shall be carried out in a test chamber having a cross sectional area of not less than 4 times that of the battery face normal to the air flow which shall be that face containing the connector mounting.
- The air-flow across the working section of the chamber shall be at a speed of 600 ±150mm/sec, measured before the installation of the battery. The battery shall be centred approximately vertically and horizontally within the chamber.
- The battery venting tubes shall be so connected to allow the air at the test temperature to be extracted through the battery at the rate of 0.040 ± 0.004m<sup>3</sup>/min and discharged outside the test chamber.
- The battery shall be charged and prepared in accordance with **section 15** and then the temperature stabilised at +50 ± 2°C.

## SECTION 4 PERFORMANCE REQUIREMENTS

- e) The battery shall then be discharged at 266 amps  $\pm$  3amps (7 x C rate) for 5 minutes  $\pm$  3 seconds. Immediately following the discharge, and with the battery still in the chamber at  $+50 \pm 2^\circ\text{C}$ , a constant voltage charge of 28.5 volts  $\pm$  0.2 volts shall be applied for  $10 \pm 0.1$  hours. The charging current shall be recorded at one second intervals for the initial five minutes – thereafter the current and centre-cell temperature shall be recorded every ten minutes. The voltage shall be recorded throughout the discharge period.
- f) At the completion of the 10-hour charging period, the battery shall stand on open circuit for between 16 and 24 hours at a temperature of  $23 \pm 2^\circ\text{C}$ , examined for physical damage, prior to being discharged at 38 amps  $\pm$  0.4 amps to a battery end voltage of 20.0 volts.
- g) The battery shall be considered to have met this requirement if the following conditions are satisfied:
  - During the constant voltage charge, the charging current shall not increase from the minimum value during this period by more than 7.6 amps.
  - The temperature during the 10 hour charge period shall not exceed  $70^\circ\text{C}$ .
  - The final discharge at 38amps  $\pm$  0.4 amps to 20V shall not be less than 48 minutes.

### 16.11 Short Circuit Current

- a) The battery shall be charged and prepared in accordance with **section 15** and then stabilised at a temperature of  $23 \pm 2^\circ\text{C}$ .
- b) The test circuit shall employ the appropriate mating connector and cable with a switch and ammeter shunt suitable for the anticipated short circuit current. The total resistance of the test circuit, including mating connector, when measured at room ambient temperature, shall be  $1.5 \pm 0.5$  milliohms.
- c) The test circuit shall be connected to the battery with the current and terminal voltage measured against time for a period of 60 seconds.
- d) The peak current and last recorded current are to be noted and, if the battery becomes open-circuit, the duration from the start of the application of the short-circuit, and the current immediately prior to failure, are also to be recorded.
- e) During the test, any resultant debris or fragmentation shall be contained within the battery casing and there shall be no subsequent ignition of gases within the battery.
- f) Following the test, the battery shall be examined for damage prior to being subjected to a capacity test as detailed in **section 16.1**. During the capacity test the battery shall exhibit safe performance.



## SECTION 4 PERFORMANCE REQUIREMENTS

### 17 ENVIRONMENTAL TESTING

#### 17.1 Unspillability

- a) The battery shall be in a fully charged condition with the electrolyte adjusted in accordance with the manufacturer's instructions.
- b) It shall then be charged at a constant potential of 28.5 volts  $\pm$  0.2volts for a further period of 2 hours.
- c) The charging shall be continued during the test and the battery shall be securely attached to a jig capable of being rotated about its horizontal axis, the battery being centralised with its major length above and parallel to the axis of rotation.
- d) The platform and battery shall be rotated 10 times with a pause of 30 seconds after each half revolution. The speed of rotation shall be equivalent to 1 revolution per 5 seconds.
- e) The test shall be repeated with the vertical axis of the battery centralised over the axis of rotation.
- f) There shall be no spillage of electrolyte from the battery and shall satisfy the insulation test values when tested in accordance with **section 16.3**.

#### 17.2 Ventilation

- a) The battery shall be secured by its normal mounting and an air-flow of  $0.040 \pm 0.004\text{mm}^3/\text{min}$  shall be extracted from each outlet port in turn.
- b) With the battery cover fitted in the normal manner, the venting battery chamber shall be subjected to a negative pressure of 65KPa using suitable blanking arrangements.
- c) With the airflow being extracted from the battery as detailed above, the pressure drop across the battery shall not exceed 3.5KPa.
- d) With the battery being subjected to this negative pressure as detailed in **17.2 (c)**, the battery chamber shall withstand this pressure without derangement.

#### 17.3 Topple Test

- a) The battery shall be placed upright on a horizontal steel plate 6mm to 12mm thick which has been wet-floated, set and bolted to a concrete block not less than 0.7m thick.
- b) The battery shall then be pivoted about each edge in turn until either,
  - the opposite edge of its base is raised to a height of 100mm, or
  - the horizontal axis of the battery makes an angle of  $45^\circ$  with the steel plate

which ever occurs first, then freely dropped from this position.

- c) The battery shall be inspected for any damage prior to being subjected to a Rated Capacity test (**section 16.1** refers).

**SECTION 4 PERFORMANCE REQUIREMENTS**

**17.4 Vibration**

- a) The fully charged battery shall be mounted with the base of the battery in a horizontal plane irrespective of the axis of vibration. It shall be secured directly onto the vibration generator table by its normal methods of mounting as shown in **Figure 2**.
- b) An initial resonance search test shall be carried out with a sweep rate of 0.1 octaves per minute, using the following sinusoidal conditions:

5Hz to 10Hz (2.5mm constant amplitude)  
 10Hz to 60Hz (1.5gn constant acceleration)  
 60Hz to 85Hz (0.075mm constant amplitude)  
 85Hz to 1000Hz (2.0gn constant acceleration)

- c) The sweep shall be carried out in each of the three mutually perpendicular axes and throughout the search the frequencies at which resonances occur shall be noted.
- d) If resonance has been noted, then the battery shall be vibrated for a period of 1 hour at each fundamental resonant frequency in the axis where resonance was found.
- e) The battery shall then be charged in accordance with the manufacturers instruction and then subjected to a discrete frequency endurance test in the x and y axis (see **Figure 2**) as follows:-

17Hz at ± 0.016ins for 10.9hrs  
 17Hz at ± 0.038ins for 2.73hrs  
 34Hz at ± 0.012ins for 5.43hrs  
 34Hz at ± 0.019ins~for 1.37hrs  
 104Hz at ± 0.005ins for 8.9 hrs

- f) On completion of vibration in the x and y axis, the battery shall be discharged at 38 amps ± 0.2 amps to a battery end voltage of 20V.
- g) The battery shall then be charged in accordance with the manufactures instruction and vibrated in the z axis (vertical) as follows: -

17Hz at ± 0.08ins for 10.9hrs  
 17Hz at ± 0.202ins for 2.73hrs  
 34Hz at ± 0.012ins for 5.43hrs  
 34Hz at ± 0.019ins for 1.37hrs  
 104Hz at ± 0.005ins for 8.9 hrs

- h) During the vibration test the battery shall be discharged at 1.4 amps ± 0.1 amps, The voltage and current shall be continuously recorded, such that, any variation on interruption can be detected. The response time of the monitoring equipment shall be no more than 0.5 seconds.
- i) The battery shall then be given a capacity test as detailed in **clause 16.1**

**SECTION 4 PERFORMANCE REQUIREMENTS**

- j) The battery shall satisfy the following criteria,
  - The voltage and current recordings obtained during the final discharge shall show no interruptions or voltage fluctuations.
  - The battery shall have not suffered any damage or leakage of electrolyte.
  - The battery when subjected to the rapid discharge test detailed in **section 16.5**.

**17.5 Cell Leakage**

- a) When supported in the battery case, each cell in the battery shall be subjected to an internal air pressure of 14KPa (140cm water gauge), or maximum relief pressure, whichever is the greater for 15 seconds.
- b) There should be no detectable drop in air pressure during this 15-second period.

**17.6 Acceleration**

A fully charged battery shall be secured to a test jig, which allows the battery to be secured by its normal method of fixing (see **Figure 2**). This jig in turn shall be fixed to the centrifuge.

The acceleration conditions shall be as follows and shall be applied in each axis (see **Figure 2**) for not less than 1 minute.

**17.6.1 Normal Condition**

x and y:	+2gn to -2gn
z axis :	+4.5gn to -2gn

During the test, the battery shall be discharged at 3.8 amps  $\pm$  0.4 with the battery voltage and current continuously recorded.

**17.6.2 Crash Condition**

x and y axis:	+9gn to -9gn
z axis	+4gn to -4.5gn

During the normal acceleration test, there shall be no interruptions of the output and no abnormal variation of voltage or current. On completion of the test, there shall be no apparent damage or leakage of electrolyte from the battery.

## SECTION 4 PERFORMANCE REQUIREMENTS

### 17.7 Explosion Containment

- a) With the fully-charged battery mounted by its normal fixing, see **Figure 2**, it shall be brought to the overcharge condition with a charging rate of 19 amps  $\pm$  0.2amps. After no less than 5 minutes at this rate the gases within the casing shall be ignited by a suitable method.
- b) All debris or fragmentation shall be contained within the casing and there shall be no subsequent ignition of the battery.

### 17.8 Fluid Contamination

Samples of all materials used for the external surfaces of the battery case shall be subjected to the spray and immersion tests in accordance to RTCA/DO-160D, **section 11** – Fluids Susceptibility.

### 17.9 Storage

- a) One battery shall be stored under temperate conditions of  $+20 \pm 10^{\circ}\text{C}$ .
- b) Prior to carrying out the Group 4 tests detailed in **Table 2**, the battery shall first be temperature stabilised at  $23 \pm 2^{\circ}\text{C}$ .

## SECTION 5 PRODUCT CONFORMITY CERTIFICATION

### 18 GENERAL REQUIREMENTS

The Product Conformity Certification requirements defined in **section 2** of Def Stan 61-21 are applicable to this supplement.

### 19 PRODUCT CONFORMITY TEST REQUIREMENTS

The test schedule shown in **Table 2** shall apply for product conformity certification. All of the tests shall be carried out in the stated order. The number of samples for each test shall be in accordance with the suppliers quality procedures.

#### 19.1 Interim Certification

Interim certification may be considered after the satisfactory completion of the tests shown shaded in the Group 1 to 3 test groups given in **Table 2**.

#### 19.2 Periodic Revalidation

In order to maintain the validity of Product Conformity Certification, key aspects of critical electrical performance shall be verified periodically for batteries conforming to this specification.

For all batteries supplied to this specification, the test data referenced on the Product Conformity Certification for,

- Charge Acceptance
- Charge Stability
- Life Test

shall pre-date delivery by a maximum period of 3 years.

FIGURE 1

Battery Outline Drawing

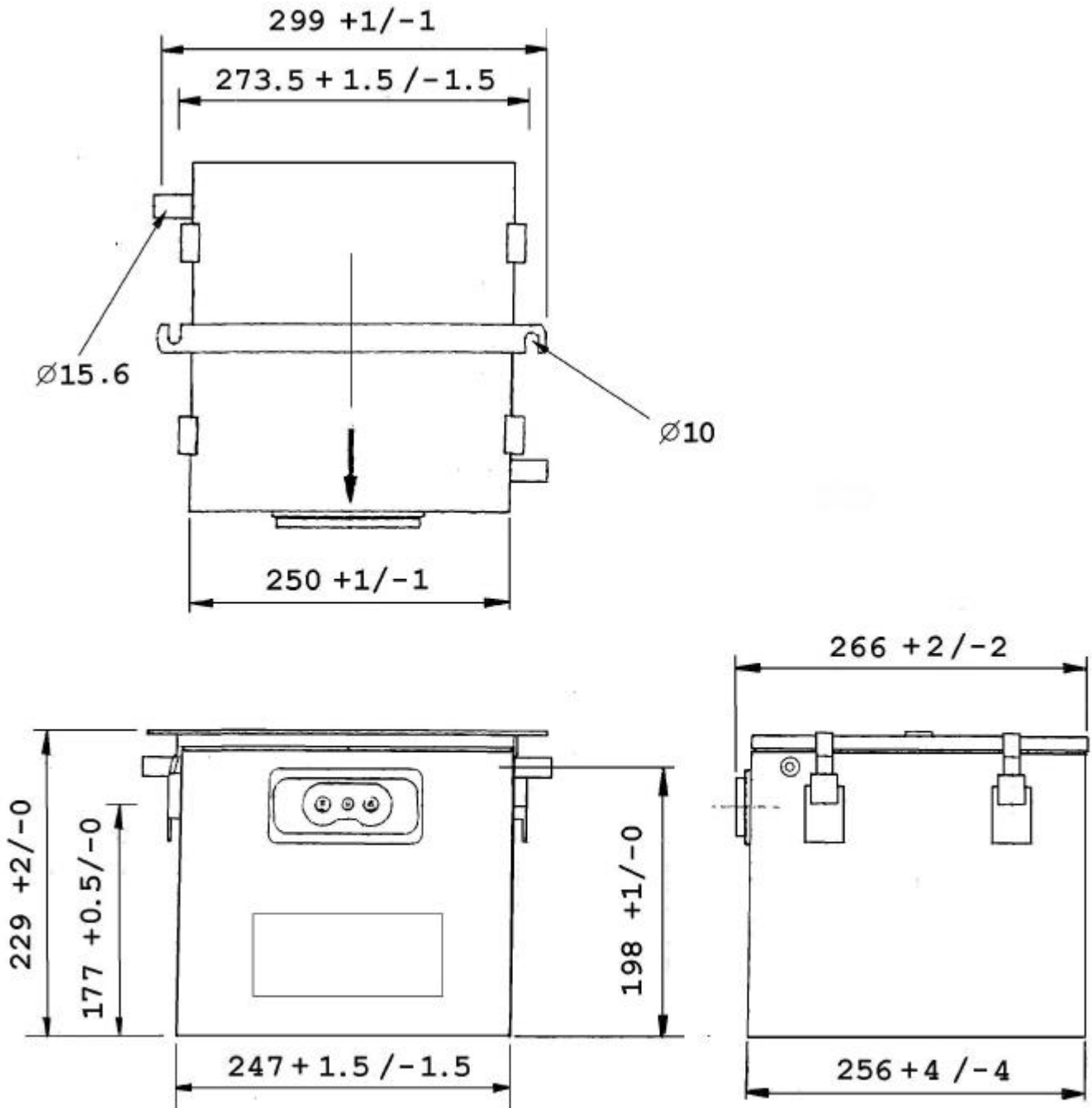

All dimensions in millimetres

FIGURE 2

Mechanical Mounting Drawing

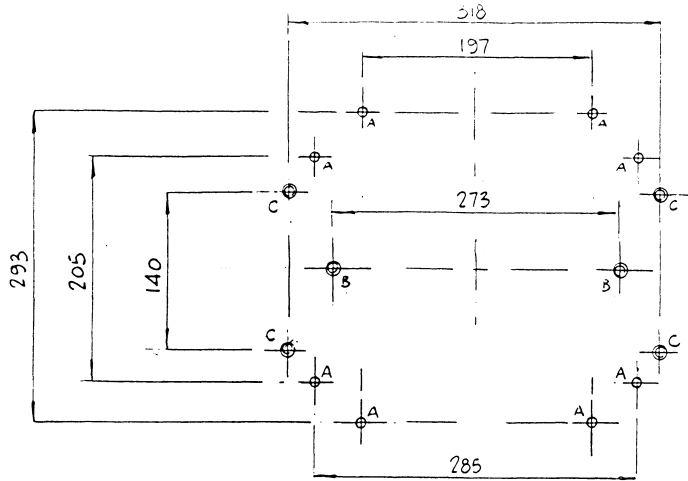

8 OFF 'A' HOLES DRILL & TAP M5  
 2 OFF 'B' HOLES DRILL & TAP M8  
 4 OFF 'C' HOLES DRILL & TAP M12

M12 NUT TIGHTEN 5Nm

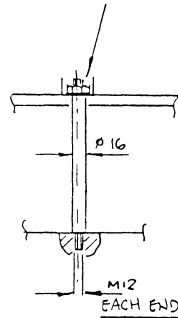

SCRAP VIEW A

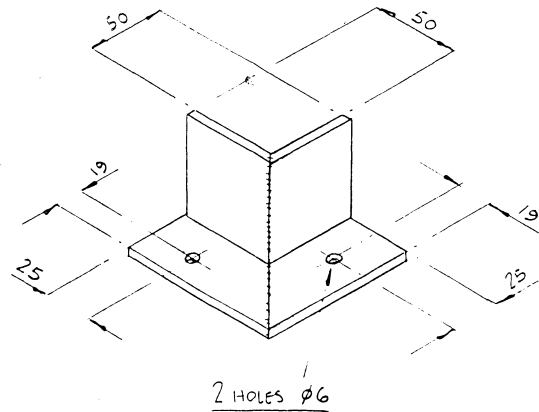

2 HOLES  $\phi 6$

CORNER BRACKET - 4 OFF  
 MATERIAL :- 38.1 x 38.1 x 3.2 ANGLE.  
 WELDED AS SHOWN.

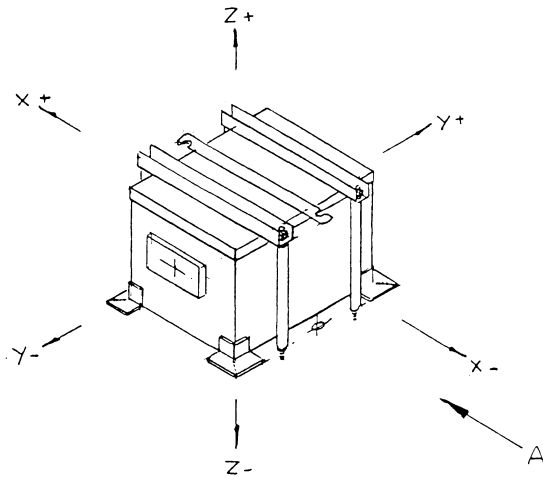

TABLE 2

## Product Certification Test Sequence Summary

Test No	Specific Test	Relevant Clause	Group			
			1	2	3	4
			No of Batteries			
1	1	1	1			
1	Storage	17.9				X
2	Physical Examination	9 - 11	X	X	X	X
3	Cell Leakage	17.5	X	X	X	X
4	Rated Capacity	16.1	X	X	X	X
5	Capacity at low temperature	16.2		X		
6	Insulation Resistance	16.3	X	X	X	X
7	Unspillability	17.1	X			X
8	Ventilation	17.2			X	
9	Charge Retention	16.4	X	X		X
10	Rapid Discharge Capacity	16.5	X			X
11	Low Temperature Starting Capability	16.6			X	
12	Life Test	16.7			X	X
13	Internal Resistance	16.8		X		
14	Charge Acceptance	16.9		X		
15	Charge Stability	16.10		X		
16	Short Circuit Current	16.11		X		
17	Topple	17.3	X			
18	Vibration	17.4	X			
19	Cell Leakage after vibration	17.4	X			
20	Normal Acceleration	17.6.1	X			
21	Cell Leakage after acceleration	17.6	X			
22	Crash Acceleration	17.6.2	X			
23	Explosion Containment	17.7	1-off, any sample			
24	Fluid Contamination	17.8	Finished material sample to be tested			

**NB.** Shaded areas indicate the tests required for interim certification (Section 19.1 refers)



**20 HAZARD CLASSIFICATION AND TRANSPORTATION REQUIREMENTS**

For transportation considerations the manufacture shall state within the Declaration of Conformity the following:

1. The manufacturer shall declare that the battery is tested to and is compliant with Hazard Classification 2800 (Wet Non Spillable) in the latest edition of UN document ST/SG/AC.10/1 (Recommendations on the Transportation of Dangerous Goods).
2. Compliance with the range of UK National and Multi-National mode specific transport regulations stipulated in Def Stan 61-21.
3. Reference to the manufacturing data package (build standard) for materials, piece parts and processes used in the battery construction.

**SECTION 6 MARKING REQUIREMENTS**

**21 MARKING**

Marking shall be in accordance with DEF STAN 61-21 with the addition of a serial number, polarity indication and a statement of compliance to Hazard Classification 2800 (see **clause 28**).

**SECTION 7 PACKAGING AND LABELLING REQUIREMENTS**

**22 GENERAL REQUIREMENTS**

In addition to the packaging and labelling requirements stated in the contract, all packaging and labelling shall comply with the requirements of the civil dangerous goods transport regulations governing land, sea and air modes of transport. Except where specified in the contract or excluded within the regulations this shall include packaging requirements for mixed passenger and cargo aircraft.

All levels of packaging shall also include:

1. The product NATO Stock Number.
2. The date of manufacture.

**© Crown Copyright 2004**  
**Copying Only as Agreed with DStan**

Defence Standards are Published by and Obtainable from:

Defence Procurement Agency  
An Executive Agency of The Ministry of Defence  
UK Defence Standardization  
Kentigern House  
65 Brown Street  
GLASGOW G2 8EX

**DStan Helpdesk**

Tel 0141 224 2531/2  
Fax 0141 224 2503  
Internet e-mail [enquiries@dstan.mod.uk](mailto:enquiries@dstan.mod.uk)

**File Reference**

The DStan file reference relating to work on this standard is D/DStan/61/21/31.

**Contract Requirements**

When Defence Standards are incorporated into contracts users are responsible for their correct application and for complying with contractual and statutory requirements. Compliance with a Defence Standard does not in itself confer immunity from legal obligations.

**Revision of Defence Standards**

Defence Standards are revised as necessary by up issue or amendment. It is important that users of Defence Standards should ascertain that they are in possession of the latest issue or amendment. Information on all Defence Standards is contained in Def Stan 00-00 Standards for Defence Part 3 , Index of Standards for Defence Procurement Section 4 'Index of Defence Standards and Defence Specifications' published annually and supplemented regularly by Standards in Defence News (SID News). Any person who, when making use of a Defence Standard encounters an inaccuracy or ambiguity is requested to notify the Directorate of Standardization (DStan) without delay in order that the matter may be investigated and appropriate action taken.